

Ream Dispenser

ASSEMBLY INSTRUCTIONS

Having assembly trouble? View the instructional video at: www.finditproducts.com
STOP! - PLEASE DO NOT RETURN THIS PRODUCT TO THE RETAILER OR RESELLER
CONTACT Find It™ Products directly at (866)-459-2400

Parts



(A)
Top Assembly



(B)
Base

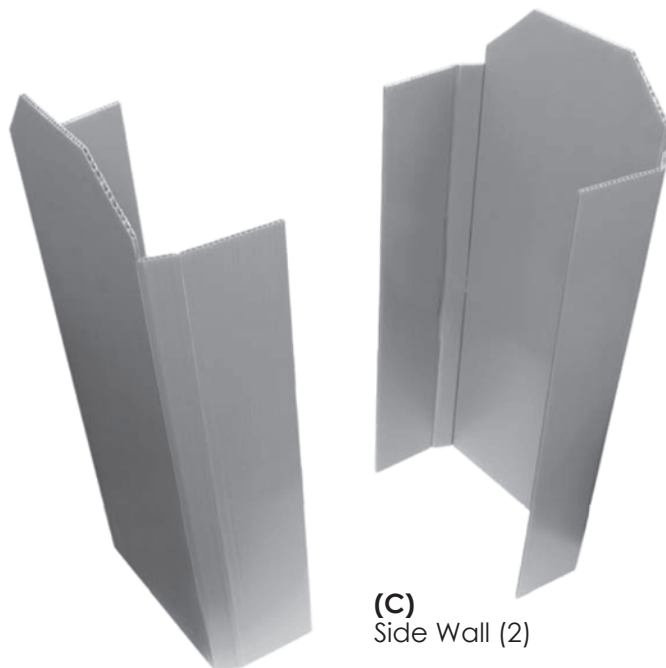

(C)
Side Wall (2)

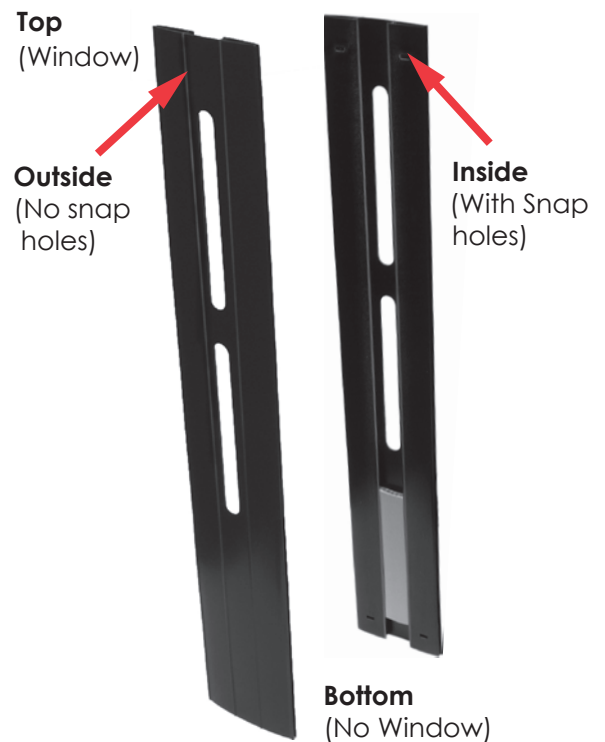

(D)
Wall Channel (2)

STEP 1

Place top assembly **(A)** upside down and insert side walls **(C)** into top assembly **(A)**.

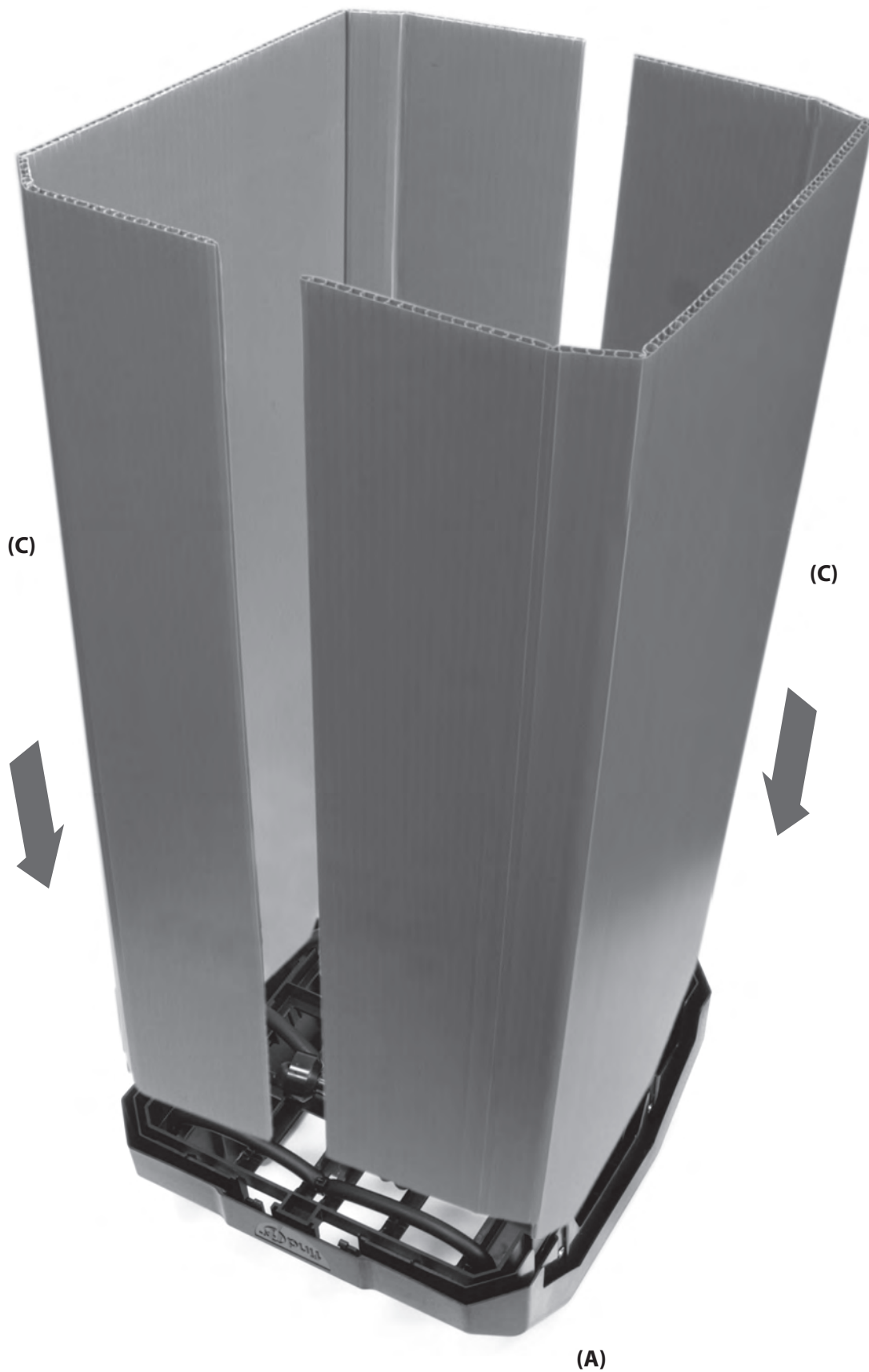

STEP 2

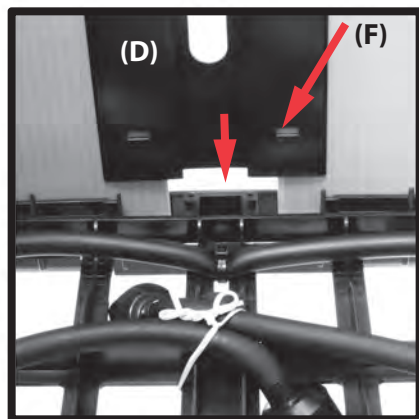
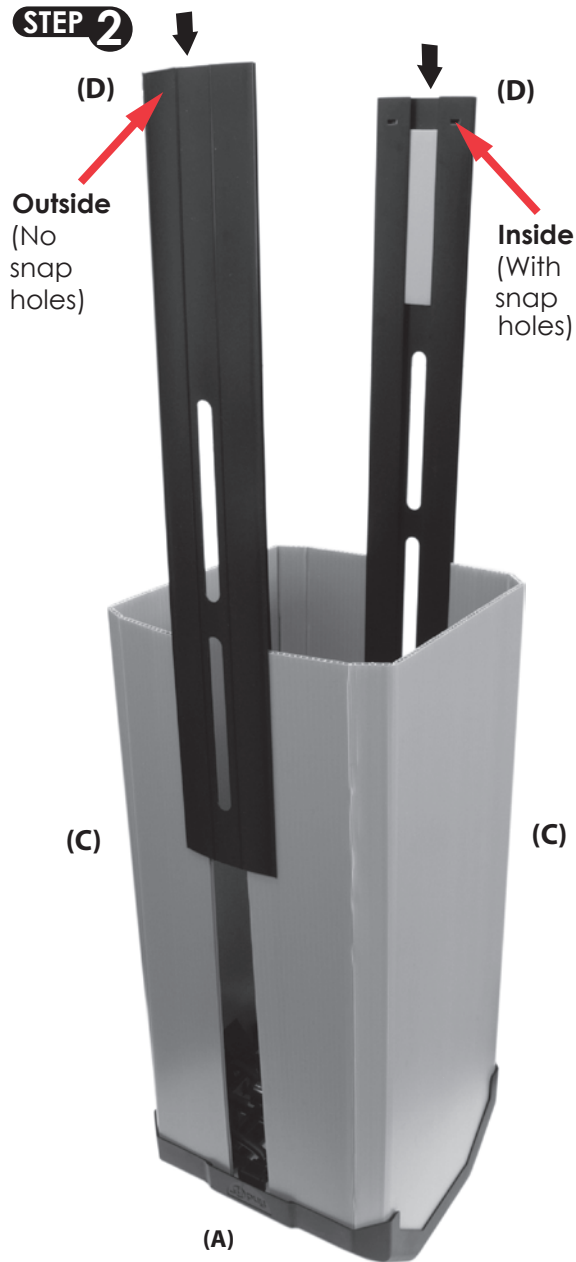

Slide wall channels (D) over the edges of the side walls (C) and into top assembly.

Note: Insert the wall channels with the snap holes (F) facing inward.

STEP 3

Keeping top assembly (A) upside down, insert base (B) over wall channels (D) and side walls (C).

Note: Position the base hooks to line up with the snap holes.

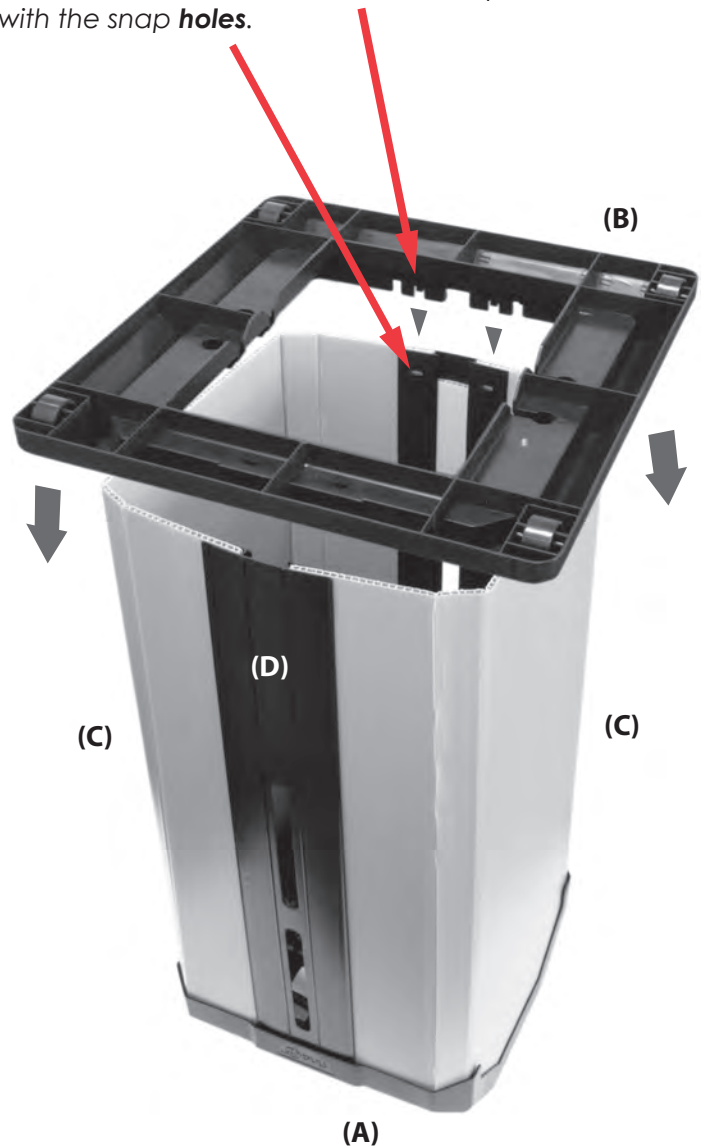

STEP 4

Carefully remove twist ties (H) securing tension bands (G).
NOTE: DO NOT remove cable ties (J).

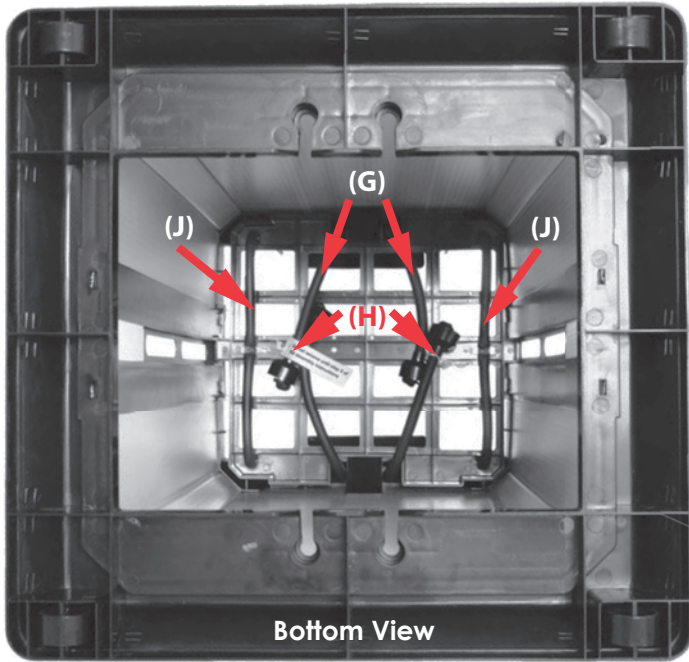

STEP 5

Hook 4 tension bands (G) into corresponding slots (I) in base (B).

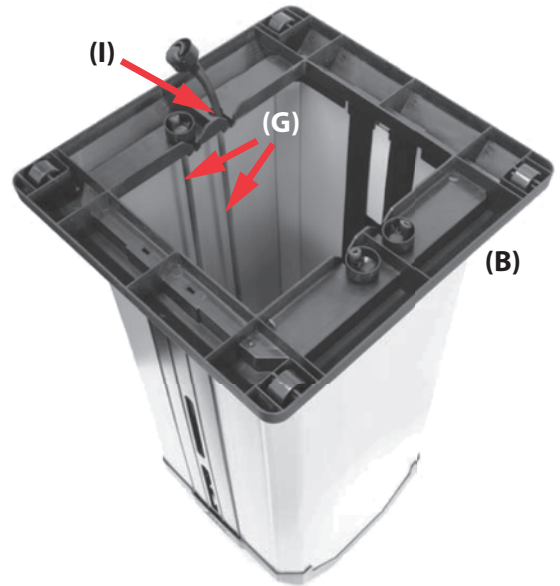

STEP 6

Set ream dispenser upright.

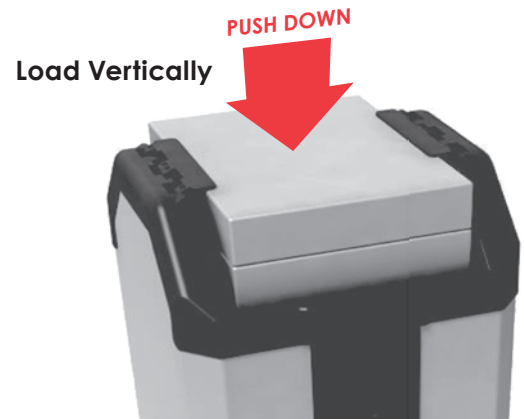

Having assembly trouble? View the instructional video at: www.finditproducts.com
STOP! - PLEASE DO NOT RETURN THIS PRODUCT TO THE RETAILER OR RESELLER
CONTACT Find It™ Products directly at (866)-459-2400